

NX STAMI Nitrates™

Optimizing nitric acid
production



NEXTCHEM

MAIRE Sustainable Technology Solutions

About NEXTCHEM

NEXTCHEM is MAIRE's company dedicated to Sustainable Technology Solutions. Leveraging our profound expertise in nitrogen, hydrogen, carbon capture, fuels, chemicals, and polymers, we deliver groundbreaking solutions and processes that fully enable the energy transition.

Building on the rich legacy of our group for over 70 years, we are dedicated to developing and offering technology solutions, processes, basic engineering designs, as well as proprietary equipment and catalysts, to drive global decarbonization efforts forward.

Maximizing energy recovery in nitric acid production.

When creating a nitric acid plant, the aim is to maximize energy recovery while minimizing the investment and greenhouse gas emissions.

We draw on many decades of knowledge and experience to deliver reliable, state-of-the-art nitric acid plants tailor-made to our customers' needs.

Our solution for an effective nitric acid plant

We have licensed a range of safe, reliable and sustainable nitrate technologies and built over 40 nitric acid plants worldwide.

Depending on clients' preferences, we offer best-in-class, mono- and dual-pressure nitric acid technologies for a wide range of plant capacities up to 600 MTPD (mono-pressure) or 2000 MTPD and above (dual-pressure).

NX STAMI Nitrates™

Reducing total cost of ownership

Applications

Plant optimization services

Plant inspections

Equipment replacement

Revamp studies and revamps

High-fidelity
Operator Training Simulator

Your benefits

- 1** High tail gas temperature boosts N_2O decomposition without adding external agents like natural gas
- 2** Extra power generation in the expansion turbine and additional heat recovery minimize energy loss through tail gas emissions
- 3** Corrosion prevention by design promotes process safety and reliability

Mono pressure technology

This technology can be applied on nitric acid plant design up to 600 MTPD (100% HNO₃).

The mono pressure nitric acid production process operates at 8 bar (a) and is highly efficient.

This streamlined process focuses on maximizing energy recovery and reducing emissions in nitric acid production.

- A** Compressor train
- B** Burner
- C** Tail gas heater
- D** Waste heat boiler
- E** Absorption column
- F** Bleaching column
- G** N₂O/NO_x abatement reactor

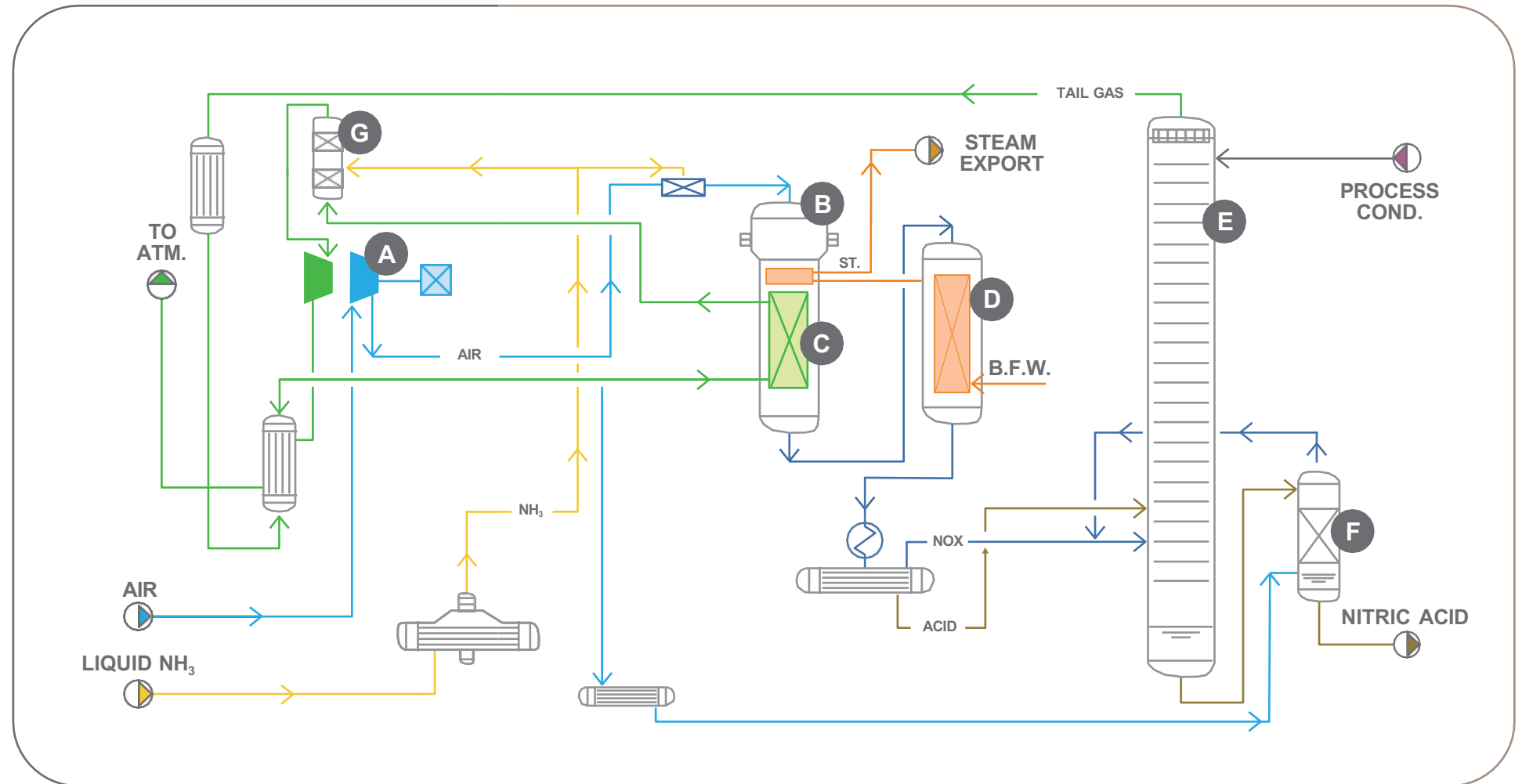

Dual pressure technology

This technology can be applied on nitric acid plant design up to 2000 MTPD (100% HNO₃) for single trains.

The dual pressure nitric acid production process is an advanced method that operates at two different pressure levels.

This dual pressure process efficiently produces nitric acid, emphasizing energy recovery and emission reduction at two distinct pressure stages.

- A** Compressor train
- B** Burner
- C** Tail gas heater
- D** Waste heat boiler
- E** Absorption column
- F** Bleaching column
- G** N₂O/NO_x abatement reactor

